

Insertion

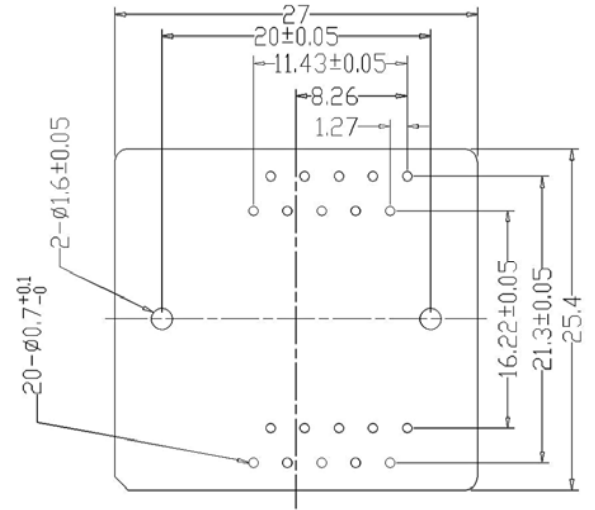

PCB PATTERN (Top View)

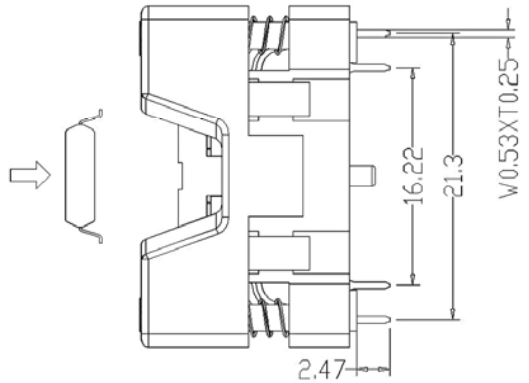
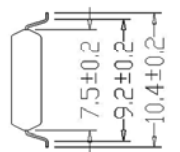
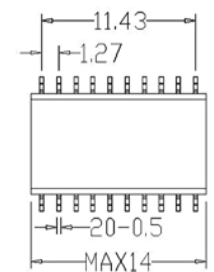
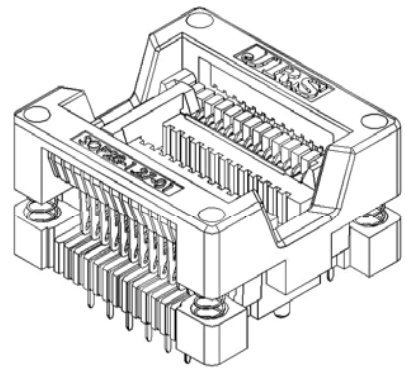
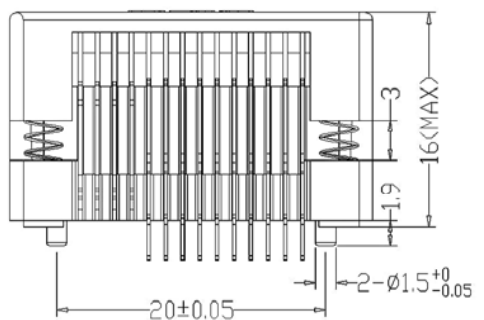

APPL ICABLE IC

1、 MATERIAL AND FINISH

- 1、 SOCKET LID :PEI
- 2、 SOCKET BASE :PEI
- 3、 CONTACTS :BeCu,SELECTIVE Au-AuFLASH OVER NI PLATING
- 4、 SPRINGS :STAINLESS STEEL ,PASSIVATED

2、 PERFORMANCE

- 1、 Insulation Resistance : 1000MΩ Min.AT DC 500V
- 2、 Dielectric Withstanding Voltage For 1 minute AT AC 700V
- 3、 Contact Resistance 30mΩ MAX. at 10mA and 20mV MAX.(Initial)
- 4、 Operation Temperature -65°C~+150°C
- 5、 Contact Force 50g Per Pin (Normal)
- 6、 Life Span 10,000 Times (Mechanical)
- 7、 Operation Force 2.0 Kg MAX

△ C				DWG NO		PART NAME	SOP-20(28)-1.27-01
△ B				MATERIAL	SCALE	TITLE	SOP-20(28)-1.27-01
△ A				QTY	UNIT		
REV	DESCRIPTION	DATE	CHECK	SHEET	1 OF 1	REV	01
APPLICATION				APPROVE	DATE		
ANGLES	FINISH	ROUGH	ME	0.X:±0.1	CHECK	DATE	
ALL UNSPECIFIED CHAMFERS:0.2				TRIC	0.XX:±0.05	DEGK	DATE
							20140703

JRS